



2021/10/11

ALU-SV

# Sprężyna odciążająca przejazd



## TYP RPB 30

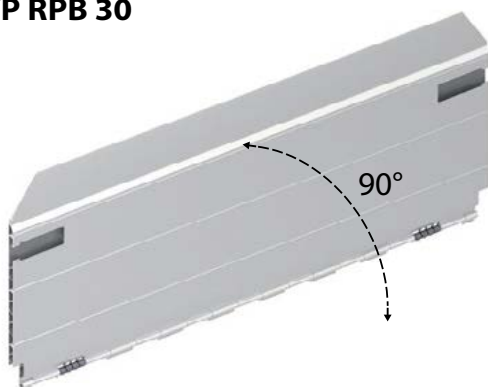

2900000018

Przejazd ALU 30 950mm frezowany 2500kg

EN AW 6005A

63,0 kg

m



### Informacja techniczna:

Istnieje możliwość dostarczenia przejazdu o szerokości podanej przez klienta, wysokość min. 450mm a następnie skok co 125mm.



### Elementy dodatkowe:

**2506031500 (stal):** Zamknięcie burty 681 SL 10, zn

**3F10182100 (stal):** Zamek wpuszczany, wysuwny, zn

**6600006915 (EN AW 6060):** Profil zakończeniowy U 30mm

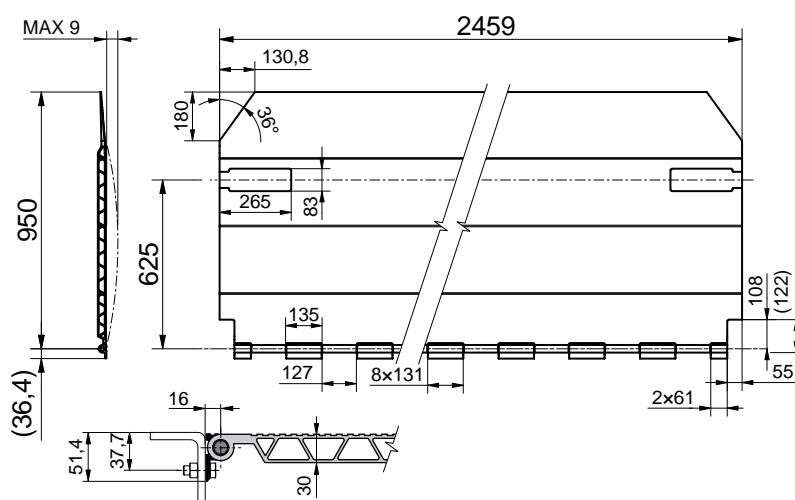



**TYP RWB**

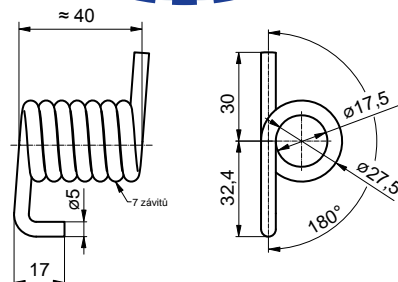
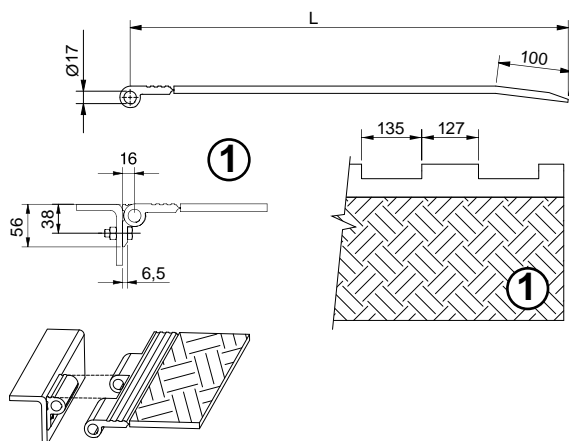

Nr katalogowy	Długość L [mm]	Szerokość l [mm]	Nośność [kg]	Waga [kg/szt]
2939131000	600	2300	2500	40
2939131001	600	2500	2500	44
2939131002	800	2300	1900	53
2939131003	800	2500	1900	58
2939131004	900	2300	1700	59
2939131005	900	2500	1700	65
2939131006	1000	2300	1500	66
2939131007	1000	2500	1500	72

62M0004505	ocynk
<b>Sprężyna przejazdu, odciążająca</b>	
stal 12 090	0,05 kg m

